

## 8 Piece Lok-Typ™ Torx Removers



### Information

- Special Lok-Typ™ design of a Torx Plus head, twist body with teeth and tap shape allows for a secure hold and easy removal of stuck torx fittings.
- High efficiency to remove damaged objects in a wide range of applications.
- Stripped Torx / Torx plus / Torx security inside.
- Torx / Torx plus / Torx security inside.
- Hex inside (not stripped).
- Stripped round inside.
- Stripped hex inside.
- Round inside.

### Precautions

Always wear safety gear.  
Working in a clean and safe environment.  
This task should be carried out by trained personnel.  
Make sure to consult manufacturers manual.  
Do NOT use with air tools.

## Information

- DO NOT use on normal bolts, ONLY use when removing hard-to-remove or broken bolts.
- DO NOT use an air wrench to operate the extractors.

- Special design of torx plus head, twist body with teeth and tap shape.
- High efficiency to remove damage objects as below.
- Hex inside (not stripped).
- Stripped hex inside.
- Round inside.
- Stripped round inside.
- Torx / torx plus / torx security inside.
- Stripped torx / torx plus / torx security inside.
- Wide application

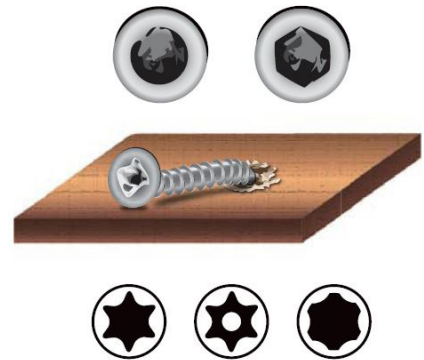

## Specifications

- Material: S2.
- Hardness: 58-60 degree.

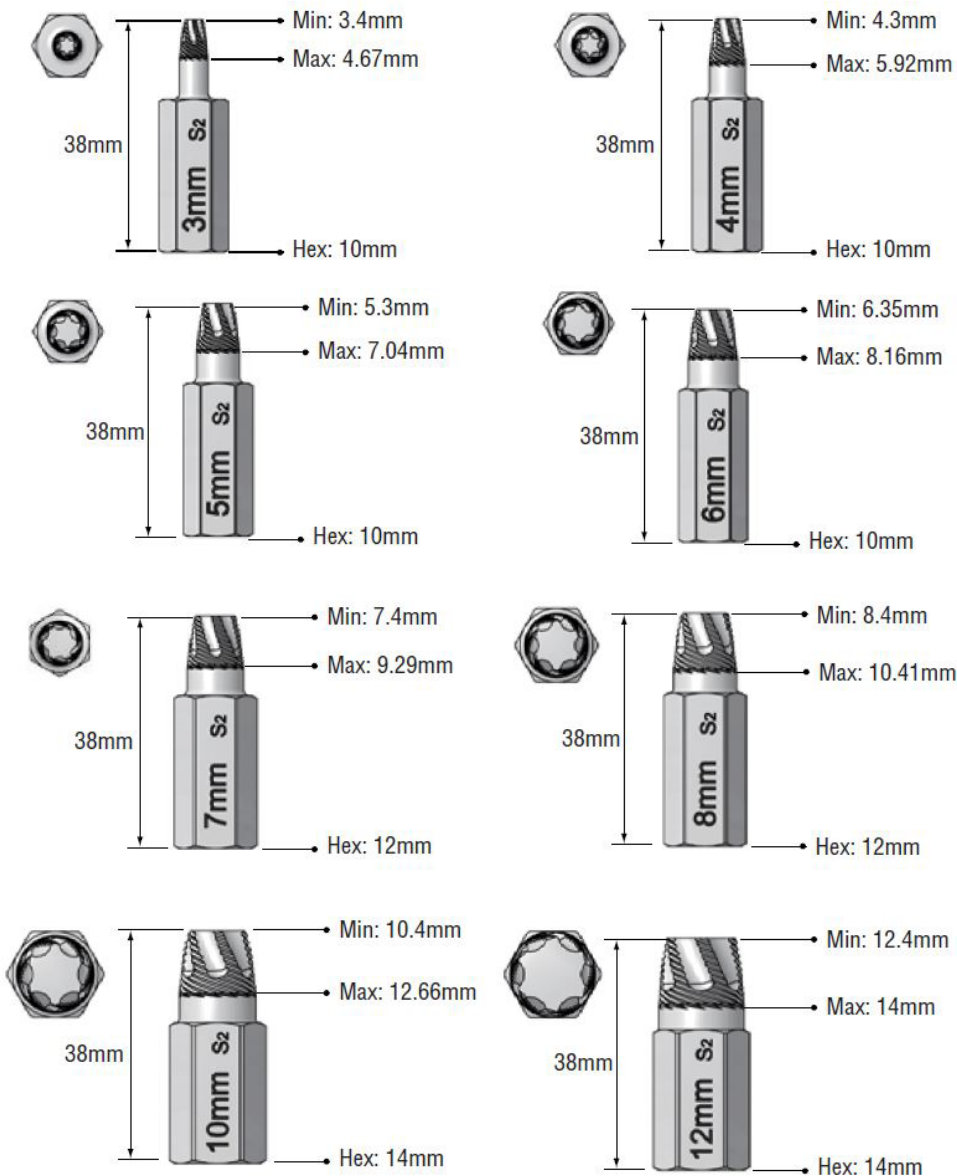

Patent Status	
EU	Patented
Japan	Patented
Taiwan	Patent Pending
Germany	Patent Pending
USA	Patent Pending
UK	Patent Pending
China	Patent Pending

## Instructions

---

For Damaged/Stripped Object:

**Step 1**

Choose a suitable size of extractor. (Fig.1)

**Step 2**

Install the extractor on object. (Fig.1)

**Step 3**

Remove the object. (Fig.2)

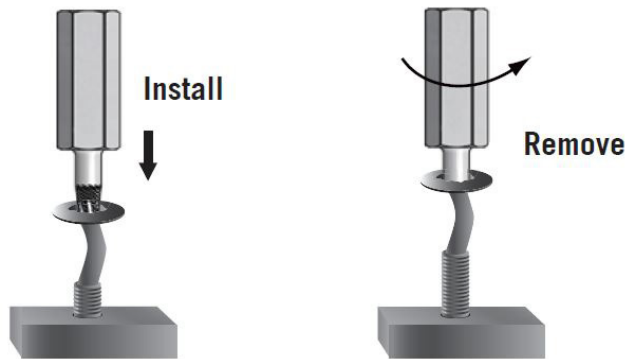

When the object is cut:

**Step 1**

Drill a hole on stripped object. (Fig.1)

**Step 2**

Choose a suitable size of extractor. (Fig.2)

**Step 3**

Install the extractor on object. (Fig.2)

**Step 4**

Remove the object. (Fig.3)

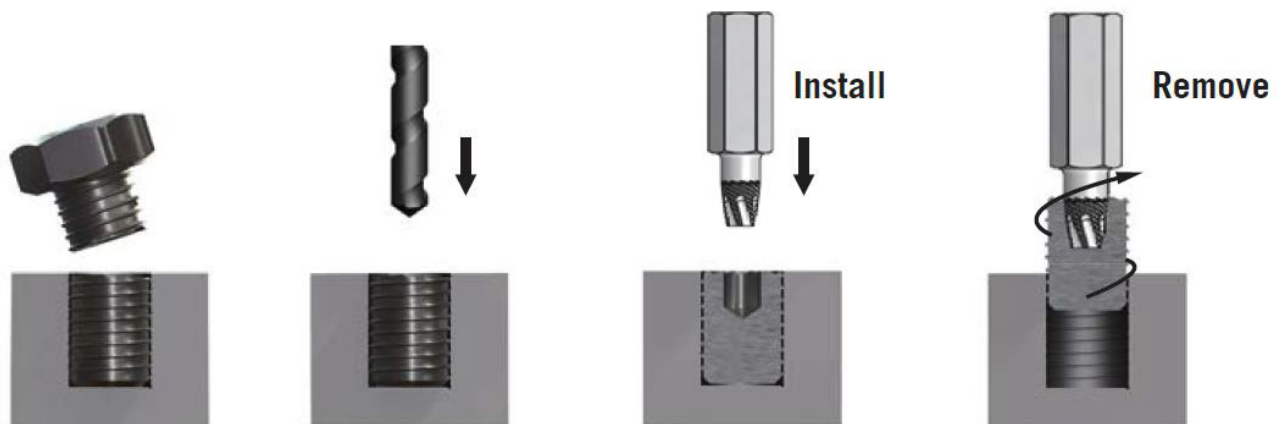

## Warranty

---

If you are unsure on how to use the item please contact us. If it were to fail due to a manufacturing fault or poor workmanship we will repair or replace it. Please contact your local dealer in the event you need to send the item back. You can also make a repair/replacement request on our website and download & complete the form online. Normal wear and tear along with misuse will void any warranty. Consumables are not covered under warranty.

[www.welzh.com](http://www.welzh.com)

Limited **12 month** warranty



Welzh Werkzeug Ltd  
Loanwath Road  
Gretna, Scotland  
DG16 5HD  
+44 (0)1461 700120