

SEMI-UNIVERSAL DIVIDING HEAD

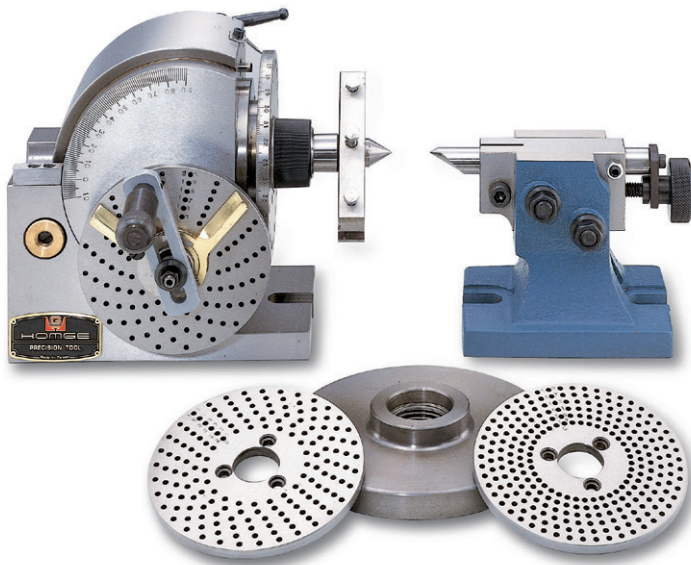

Model: BS-0, BS-1

Semi-Universal Dividing Head is a simplified type of Universal Index Center and can be used for direct and indirect dividing. No accessories for the differential dividing and spiral work are included, but the whole construction of the dividing head and tailstock are identical with those of the universal type.

The unit has a Direct Indexing Plate with 24 holes enabling the direct dividing of 2, 3, 4, 6, 8, 12 and 24 divisions. Three further Indexing Plates are provided as standard to facilitate indirect dividing of all divisions from 2 to 50 and also most useful divisions up to 380.

REMARK: " Operation and Service Manual " is included for reference

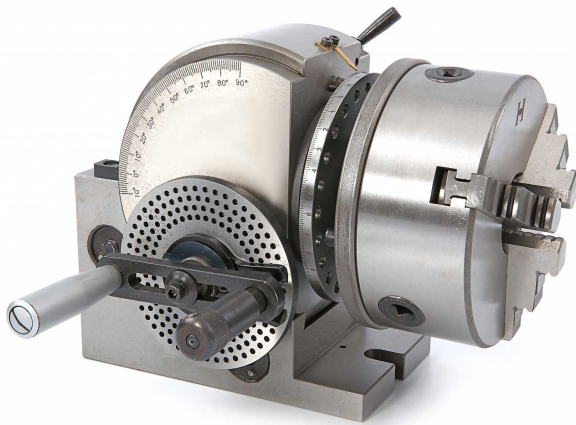

OPTIONAL ACCESSORY:

• 3-Jaw Chuck

4" or 5" 3-Jaw Chuck for BS-0

5" or 6" 3-Jaw Chuck for BS-1

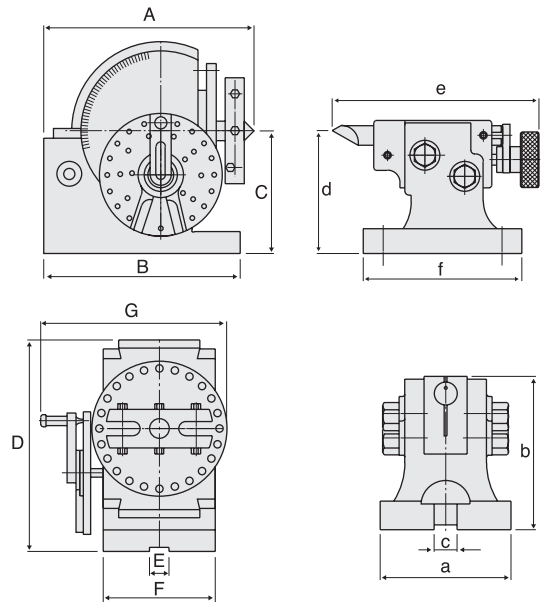

SPECIFICATIONS

Unit: mm / inch

Model	A		B		C		D		E		F		G		Weight (kg)
BS-0	189	77/16	160	619/64	100	315/16	173	613/16	16	5/8	91	337/64	140	533/64	22
BS-1	293	1111/32	210	817/64	128	53/32	220	821/32	16	5/8	114	431/64	156	69/64	32

TAIL STOCK For SEMI-UNIVERSAL DIVIDING HEAD BS-0 & BS-1

Unit: mm / inch

Model	a		b		c		d		e		f		Taper of Center	Diameter of Spindle hole
BS-0	90	335/64	105	49/64	16	5/8	100	315/16	166	634/64	127	5	B&S No.7	18
BS-1	108	41/14	134	518/64	16	5/8	128	53/32	184	71/4	150	529/32	B&S No.9	20

STANDARD ACCESSORIES: DIVIDING PLATE A, B, C.

NUMBER OF HOLES OF DIVIDING PLATE (WORM GEAR REDUCTION RATIO 40:1)

Number of holes	Plate A	15	16	17	18	19	20
	Plate B	21	23	27	29	31	33
	Plate C	37	39	41	43	47	49