



Agricultural Products

A range of high-quality agricultural lubricants designed to perform



Performance Grown Through Technology



MORRIS
LUBRICANTS
ESTABLISHED 1869

Performance Grown Through Technology

LEADERS IN AGRICULTURAL LUBRICANTS

As one of Europe's leading manufacturers of agricultural lubricants we have been delivering lubricant innovation since the very first combustion engine tractors rolled off the production line. We're constantly striving to develop the next generation of products that support the varying demands of a modern farm. Our highly-skilled, expert team works in close collaboration with the world's major agricultural OEMs to ensure that our manufacturer-approved range of products continues to meet the very latest and most stringent of global standards.

A COMPREHENSIVE RANGE OF AGRICULTURAL LUBRICANTS

Our range of agricultural vehicle products has been specifically formulated to support agricultural equipment even in the harshest of environments. These include tractors, combine harvesters and agricultural machinery utilising previous and current technologies. With ever increasing complexity of after-treatment devices (particulate filters and catalysts) our products meet the very latest emissions legislation whilst harnessing the power of the latest additive technologies to provide ultimate component protection.

Hydraulic Oils

A range of premium hydraulic oils designed for agricultural hydraulic system applications.



Designed to be subjected to extreme operating conditions and temperatures, available in a variety of viscosity grades. Our latest products contain effective anti-foam additives to facilitate the rapid release of air and reduce sponginess in system operation.

Greases

A range of high-performance greases suitable for a wide range of agricultural applications, including wheel bearings, CV joints, hydraulics and mechanical components.



Brake Fluids

High performance fluids that provide effective brake feel and operation under a wide variety of driving conditions.



Manufactured to exceed vehicle manufacturers standards, and suitable for use at high temperatures.

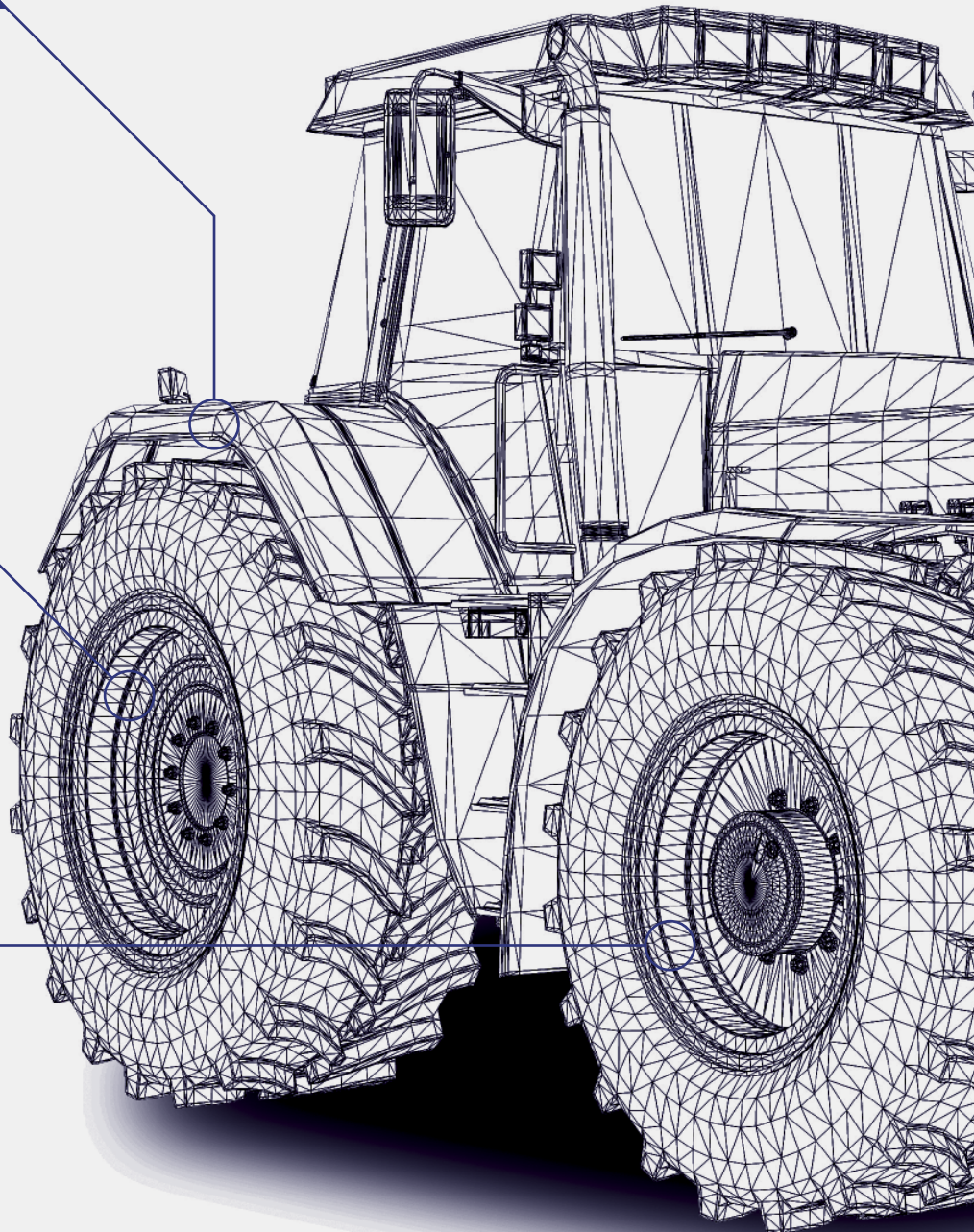

UNDERSTANDING YOUR NEEDS

Our world-renowned Research and Development department is constantly innovating to develop the next generation of world-class products for the agricultural industry. Our commitment to customer care is further demonstrated by our value-added services and infrastructure, developed through continuous collaboration with agricultural OEMs, dealerships, farmers and independent workshops.

ASK THE EXPERT

We're hugely proud of the relationships we have with our customers and are always on-hand to provide expert technical support whenever it is needed. Our expert team has extensive knowledge of lubricants and their applications, ensuring we are able to identify and recommend the perfect lubricant solutions to our customers' requirements.



Heavy Duty Diesel Engine Oils

A range of OEM approved heavy duty diesel engine oils that fulfils the needs of previous and current generation diesel engines. The range provides maximum rationalisation potential in mixed tractor and combine harvester fleets where a number of manufacturers, models and engine technologies are being used.



Coolants

Formulated specifically to provide protection all year round, these products not only ensure effective cold start, but the balanced blend of rust and corrosion additives contribute to cooling system integrity.



Gear and Transmission Oils

Fuel economy and shift comfort have put increasing demands on transmissions, driving the development of a range of products with optimised friction and wear control features.



Universal Oils

Advanced multifunctional lubricants designed to cover the majority of agricultural lubricant requirements, whilst maintaining a reduced inventory. Applications include engines, gearboxes, hydraulics and oil immersed brake systems. Developed with the latest additive technology and high-quality base oils the range offers superior operational and protective performance even in the harshest of operating conditions.

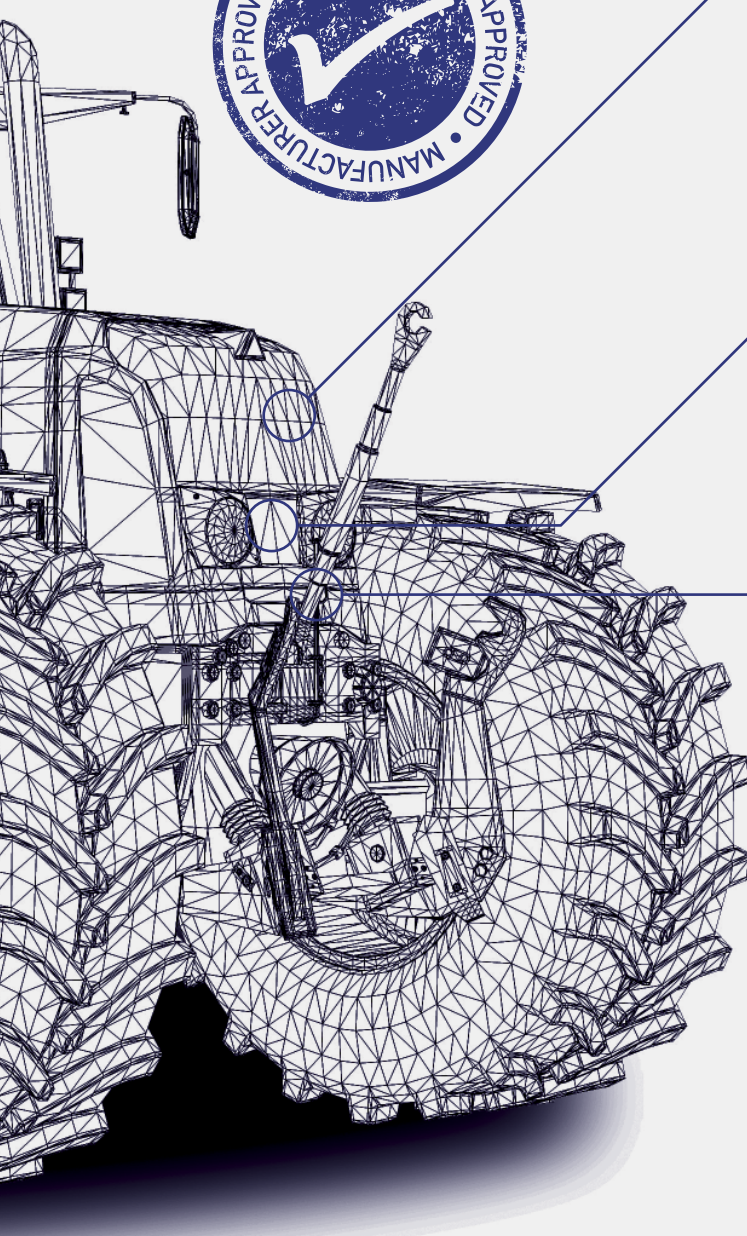

Product Specifications

HEAVY DUTY DIESEL ENGINE OILS

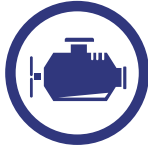

VERSIMAX HD9 10W-40

A top tier heavy duty diesel specific engine oil, designed to meet the necessary chemical limits required to maintain the efficiency of exhaust aftertreatment devices. Provides the highest level of rationalisation potential in mixed fleets where a number of manufacturers, models and engine technologies are being used.

Performance Levels:

ACEA E4 / E6 / E7 / E9, API CJ-4, MB-Approval 228.51, MAN M3477 Approval, MAN M3575 / M3271-1 Approval, MTU category 3.1 / category 2.1, Volvo VDS-4 Approval (417-0001-14-631), Renault Truck RLD-2, Renault Truck RLD-3 Approved, Mack EO-O Premium Plus Approved, Mack EO-N Premium Plus, Cummins CES 20081, CAT ECF-3, Approved to Deutz QOC IV-10 LA, Detroit Diesel 93K218, JASO DH-2.

Part number: EST

VERSIMAX HD7 10W-30

Heavy duty diesel engine oil containing an advanced additive package formulated to provide the utmost protection when operating in very severe conditions with extended drain intervals.

Performance Levels:

API CJ -4, ACEA E9, Volvo VDS-4 Approval (417-0001-15-770), Renault VI RLD-3 (Approved), Mack EO-O Premium Plus (Approved), Cummins CES 20081, Mercedes Benz 228.31, CAT ECF-3, MAN M3575, JASO DH-2.

Part number: ECN

VERSIMAX HD6 15W-40

Heavy duty diesel specific engine oil containing an advanced additive package formulated to provide the utmost protection when operating in very severe conditions with extended drain intervals.

Performance Levels:

API CJ -4 / SM, ACEA E7 / E9, CAT ECF-2 / ECF-3, Cummins CES 20076 / 20081, MAN M3575, Mack EO-O Premium Plus Approval, Detroit Diesel DFS Oil Specification 93K218 (Conformance), Mercedes Benz 228.31, Volvo VDS-4 Approval (417-0001-09-204), Renault VI RLD-3 Compliance, Deutz QOC III-10 LA Approved, MTU Type 2.1, Scania LA. Versimax HD6 15W-40 has demonstrated performance against JASO DH-1 and 2.

Part number: UPL

VERSIMAX HD4 15W-40

Advanced heavy-duty diesel engine oil, incorporating the latest additive chemistry to meet and exceed current global and OEM specifications.

Performance Levels:

ACEA E7, API CI-4/SL, Caterpillar ECF-1a, ECF-2, Cummins CES 20076 / 77 / 78, Global DHD-1, MB-Approval 228.3, MAN M3275, MACK EO-N, RVI RLD2, MTU Type 2, Volvo VDS3. Has demonstrated performance against JASO DH-1.

Part number: RVS

HYDRAULIC OILS



TRIAD HYDRAULIC OILS

A range of premium grade mineral based hydraulic oils with good anti-wear properties providing protection in the most demanding of systems.

Performance Levels:

DIN 51524 Parts 1 and 2 (DIN 51525), Sperry Vickers I-286-S, M-2950-S, Denison HF-2

Part numbers:

TRI (Triad 32), TRF (Triad 46), TRS (Triad 68)

LIQUIMATIC HV 32, 46, 68

Liquimatic HV Grades are a range of high viscosity index hydraulic oils, formulated from high quality minerals oils and the latest anti-wear technology. These grades utilise a shear stable polymer that ensures that the oils do not thin down during their working life.

Performance Levels:

DIN 51524 Part 3 (HVL/P), Sperry Vickers I-286-S3, M-2950-S, Denison HF-0 dry and wet T6C-020, Denison HF-1, HF-2, Poclairn (HV 46), AFNOR E48-603 (HV:HM), ASLE 64.1 to 64.4, 70.1 to 70.3, CETOP RP91H

Part numbers:

LHO (HV10), HVT (HV22), HVA (HV32), LHV (HV46), LHS (HV68), HVO (HV100)

LIQUIMATIC No. 4, 5, 6

A range of high quality hydraulic oils formulated with Group II base fluids, incorporating ashless additive technology and available in a variety of viscosity grades. They are rust and oxidation inhibited and will provide protection against corrosion even in the presence of seawater.

Performance Levels:

DIN 51524 Parts I and II (HLP), AFNOR NFE 48-603 Parts I and II *, Vickers Eaton I-286-S, M-2950-S, General Motors LS-02 *, SAE MS1004 *

Note. Specifications marked with an asterisk do not apply to ISO VG 10, 15, 22, 100, 150 grades.

Part numbers: LIO (1), LIT (2), LQT (3), LIF (4), LIQ (5), LIS (6), LMS (7), LIE (8)

UNIVERSAL OILS



SUPER VERSITRAC 10W-40

Superb friction properties for transmission and hydraulics, meeting the latest specifications required for transmission lubricants.

Performance Levels: API GL-4, MIL-L-2105, Allison C4, Cat TO-2 MF M1135, John Deere J20C, Ford M2C 134D, New Holland NH - 410B

Part number: SVT

SUPER FARM UNIVERSAL 10W-30

Designed to cover the majority of agricultural lubrication requirements, whilst maintaining a reduced inventory. This grade is formulated with the latest additive technology and high quality mineral oils to produce a universal lubricant for tractors, combines and agricultural machinery subjected to the severest of operating conditions.

Performance Levels: API CG-4, MB 227.1 / 228.1, Massey Ferguson M1139 / 1144 / 1145, Ford M2C159B/C, John Deere J27, ZF TE-ML 06A / 06B (Incl. 06R) / O6C / 07B,













Part number: SFU

MAGNOL STOU 15W-30

Designed to cover practically all lubrication requirements on the farm with just one grade of oil.

Performance Levels: API CF-4/SF, MIL-L-2104D, Ford M2C 121B, Massey Ferguson M1139, Ford M2C 159B, API GL-4, Massey Ferguson M1135 & M1127, Ford M2C 86A & M2C 134C, John Deere JD 20A, Case - IH MS 1207*

Part number: TOU

- | | |
|--|--|
|  Fuel Efficient |  Performance Mineral |
|  Low-SAPS |  For automated manual transmissions |
|  Mid-SAPS |  For manual transmissions |
|  Fully Synthetic |  For automatic transmissions |
|  Semi Synthetic |  For axles/differentials |
|  Special Base Oil |  For limited slip differential |

AVAILABLE SIZES

All of our products are available in a wide variety of sizes and materials suitable for various transportation and storage methods. Whatever your demands we will be able to accommodate them.



Product Specifications

GEAR AND TRANSMISSION OILS

LIQUIMATIC JDF

Multifunction fluid formulated with additives for use in the transmission and hydraulics of agricultural and material handling equipment. Liquimatic STF 60 has improved wet brake performance (oil immersed brakes), assisting in the elimination of "squawk and chatter" and therefore prolonging the life of frictional materials and other components.

Performance Levels: Ford ESN-M2C134-A/B/C/D, Ford ESEN-M2C86-A/B, Massey Ferguson M1135, GIMA M1143 Approved, CNH MAT 3525, API GL4 (L20), Volvo Transmission Oil 97303: 020 (WB101 Approval), John Deere J20C, Allison C4, Caterpillar TO-2, ZF TE-ML-03E/05F/06K

Part number: JDF

LIQUIMATIC STF 60

Multifunction fluid formulated with additives for use in the transmission and hydraulics of agricultural and material handling equipment. Liquimatic STF 60 has improved wet brake performance (oil immersed brakes), assisting in the elimination of "squawk and chatter" and therefore prolonging the life of frictional materials and other components.

Performance Levels: Ford ESN-M2C134-A/B/C/D, John Deere J20A/C, Ford ESEN-M2C86-A/B, Allison C4, New Holland NH - 410B, Caterpillar TO-2, Massey Ferguson M1135 /1143, API GL4 (L20)

Part number: STF

LIQUIMATIC DII

Recommended for use in all applications such as automatic transmissions, powershift transmissions, fluid drives, torque converters, power steering units, hydraulic systems, brake boosters, transfer boxes, PTOs and hydrostatic drives.

Performance Levels: GM Dexron II® D, Ford Mercon®, Allison C4 Ford ESP-M2C138-CJ, GM Type A Suffix A, Ford ESP-M2C166-H, ZF TE-ML 03D/04D/11A/14A/17C, MB 236.1, 236.2, 236.3

Part number: LDT

EP80W-90, EP85W-140

High performance, mineral oils for use in a wide range of transmission and differentials.

Performance Levels: All Grades API GL5, ZF TE-ML 05A/12E/16B/17B/19B/21A (Approved - EP80W-90), Listed as Scania Oil STO 1:0 (Gearboxes and axles)

Part numbers: EPE (EP80W-90), EPG (EP85W-140)

TERRAIN LS 80W-90

Formulated with a high level of extreme pressure (EP) additives and friction modifiers to protect the critical mechanisms of limited slip differentials used in heavy off-highway and agricultural equipment.

Performance Levels: API GL-5, ZF TE-ML 05C, 12C, 21C Approved, ZF TE-ML 07A, 16E

Part number: TLS



GREASES



K48 MOLY GREASE

Premium quality grease for use in all anti-friction and plain bearings subjected to high load conditions.

The incorporation of Molybdenum Disulphide imparts a high degree of wear protection against load, shock loading and dusty environments.

Contains lithium, molybdenum

Part number: KMO

K383 ANTI-SEIZE COMPOUND

K383 is a lead free anti seize compound, that enables fast and easy dismantling of components.

Contains bentone, copper

Part number: ASC

K2EP LONGLIFE

Multi-purpose lithium complex grease for lubricating all antifriction and plain bearings, shows exceptional performance even under arduous conditions and over wide operation temperature ranges.

Contains lithium complex

Part number: KLG

K41EP, K42EP, K43EP GREASES

Multipurpose grease for use in all anti-friction and plain bearings subjected to high shock load and vibration conditions.

Contains lithium

Part numbers: KFO (K41EP), KFT (K42EP), KEP (K43EP)

K40EP, K400EP, K4000EP SEMI-FLUID GREASES

This range of premium quality semi fluid greases have been designed for centralised lubrication systems. They are also suitable for anti-friction and plain bearings subjected to high load conditions and gearboxes designed to operate with a semi-fluid grease.

Contains lithium

Part numbers:

SFG (K40EP), KSF (K400EP), KFG (K4000EP)

K323 PREMIUM BLUE GREASE

Extremely sophisticated lithium / calcium base grease which incorporating polymer technology. This advanced grease has a high level of water tolerance, mechanical stability and adherence.

Contains lithium calcium













Part number: PBG

Horticulture Products

A specially formulated range of lubricants designed to keep both petrol and diesel horticultural equipment operational under severe operating conditions. These include all-terrain vehicles (ATV), strimmers, lawnmowers, chainsaws and brush cutters.



GROUND FORCE

-  Fuel Efficient
-  Performance Mineral
-  Low-SAPS
-  For automated manual transmissions
-  Mid-SAPS
-  For manual transmissions
-  Fully Synthetic
-  For automatic transmissions
-  Semi Synthetic
-  For axles/differentials
-  Special Base Oil
-  For limited slip differential

Supplementary Products



FUEL ADDITIVES

An advanced range of fuel additives designed to maintain cleanliness of fuel systems in both diesel and petrol engines. Enhancing fuel ignition quality, reducing deposits and improving fuel economy.



MAINTENANCE AEROSOLS

A carefully blended range of high performance maintenance aerosol products, including solvent cleaners, degreasers and chain lubricants. The ideal addition to the automotive workshop.



SCREEN WASHES

A range of specially formulated screen washes designed to provide excellent performance at sub-zero temperatures. Cutting through dirt and grime to leave a clean and smear free finish.



HAND CARE

A powerful range of solvent-free hand cleansers designed to remove the toughest of dirt and grime whilst providing ultimate protection to the skin. They make a perfect accompaniment to our barrier cream products in any workshop.



HYGIENE

A flexible range of cleaning products suitable for dilution and use in pressure washers to maintain cleanliness across a variety of surfaces.



AUTOMOTIVE ENGINE OILS

A range of OEM approved synthetic and semi-synthetic engine oils suitable for both petrol and diesel engines. The range fulfils the needs of previous and current generation engine technologies. Our latest synthetic products are an essential component in the operation of the latest low emission engine designs.



YOUR DEALER/DISTRIBUTOR:



FM 21756



EMS 60044



OHS 555083



ENMS 619355



MORRIS
LUBRICANTS
ESTABLISHED 1869

Castle Foregate, Shrewsbury, SY1 2EL Tel: +44 (0)1743 232 200 Email: info@morris-lubricants.co.uk

www.morrislubricants.co.uk

All the products are reflective of the latest specifications at the time of going to press and are part of a continuous development programme. The company reserves the right to change formulation and specification, without prior notice to meet the latest trends and developments in lubricant and grease technology. For more detailed information on any product and confirmation of the latest specifications contact our Technical Services Department. Full product data sheets and health and safety information is available on request.